



A division of Terry Young Ltd , New Zealand

INSTALLATION INSTRUCTIONS for HOBSON FREESTANDING WOODBURNER

April 2007

TESTED in compliance with AS/NZS 2918: 2001

- A.** Yunca recommends that competent trades persons carry out all installations (e.g. NZHHA Registered Installer), to obtain maximum performance and safe, efficient heating.
- B.** A permit is required and we suggest you check with local building inspectors as by-laws do vary from area to area.
Also notify your Insurance Company that a solid fuel heater has been installed.
- C.** Floor Protector –
1. Must extend a minimum of 300mm in front of the door aperture.
 2. Must extend at least 100mm from each side of the heater.
 3. Ash Floor Protector must be constructed of non-combustible materials, with a minimum thickness of 12mm
- D.** Seismic restraint – Heater must be restrained from seismic movement as required by NZS 7421. 10mm diameter bolting holes in the feet of the HOBSON allow restraint.
- E.** Manufacturers' recommended tested minimum clearances from combustible walls:

Tested to AS/NZS 2918 : 2001 by APPLIED RESEARCH SERVICES	Clearance
Rear Clearance (with YUNCA flue mounted shield fitted)	150 mm
Side Clearance (with YUNCA flue mounted shield fitted)	330 mm
Corner Clearance (with YUNCA flue mounted shield fitted)	90 mm

F. YUNCA Flue Kit (Tested to AS/NZS 2918:2001 Appendix F): FIG A, B & E

1. 4.2m x 150mm stainless steel flue
2. 2.4m x 250mm galvanised liner.
3. 1 x ceiling tile.
4. 1 x insulation boundary shield.
5. 3 x spider brackets.
6. 1 x weather cap & cowl.

Please Note: All joints must be sealed with flue sealing compound. Use stainless steel screws or rivets to join the flue pipe (three equally spaced places at each joint). The first length of flue pipe must be screwed to flue spigot. The required minimum flue termination height is 4.6 m above the floor protector.

G. HOBSON Flue Mounted Shield (Flue Guard) Kit (Tested to AS/NZS 2918:2001): FIG A

- 1 x 1200mm length lined back guard plus an adjustable 900mm extension.
- 1 x 1200mm length perforated front guard
- 1 x 1200mm length tertiary back guard with spacer tabs.
- 1 x Top front deflector shield (half round shape, angled when installed). Optional.

Please Note: The minimum Flue Mounted Shield height is 1200mm.

HOBSON – TYPICAL FLUE INSTALLATION (Drawings not to scale)
FIG A

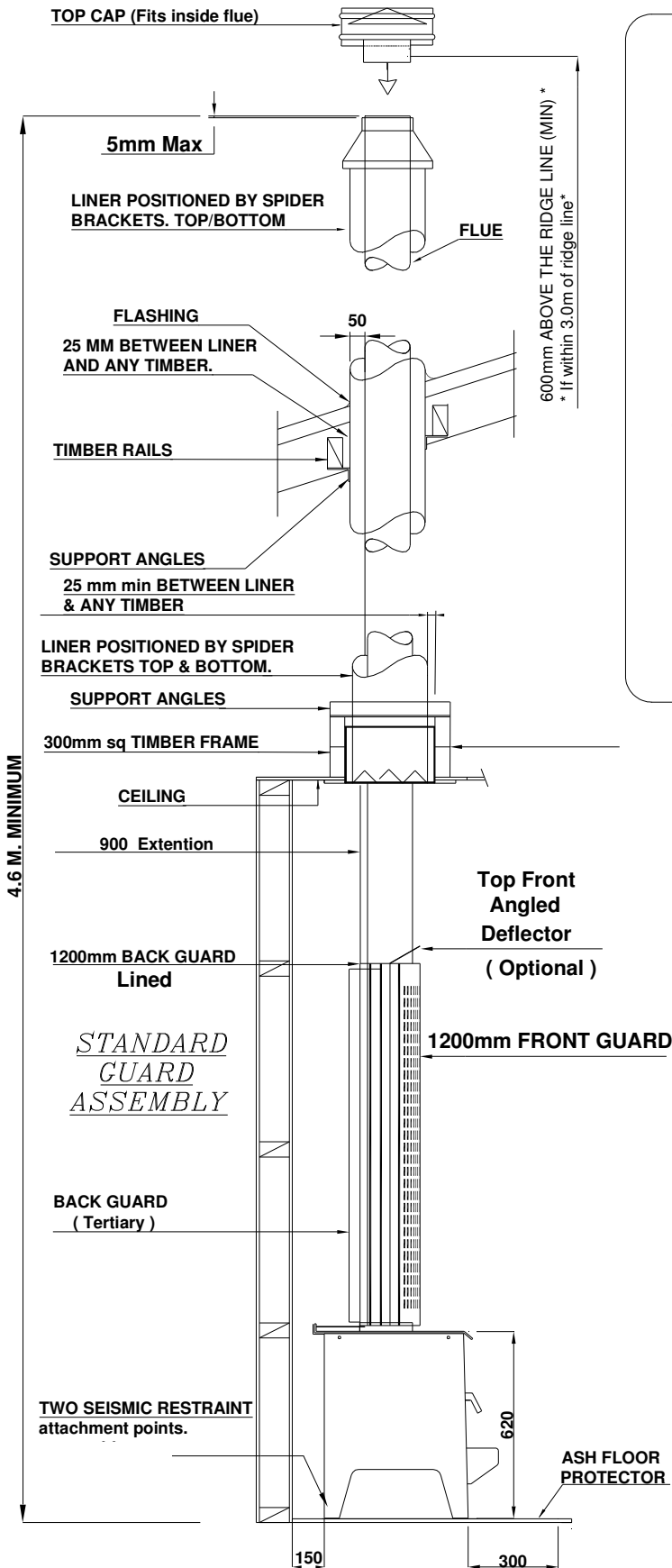
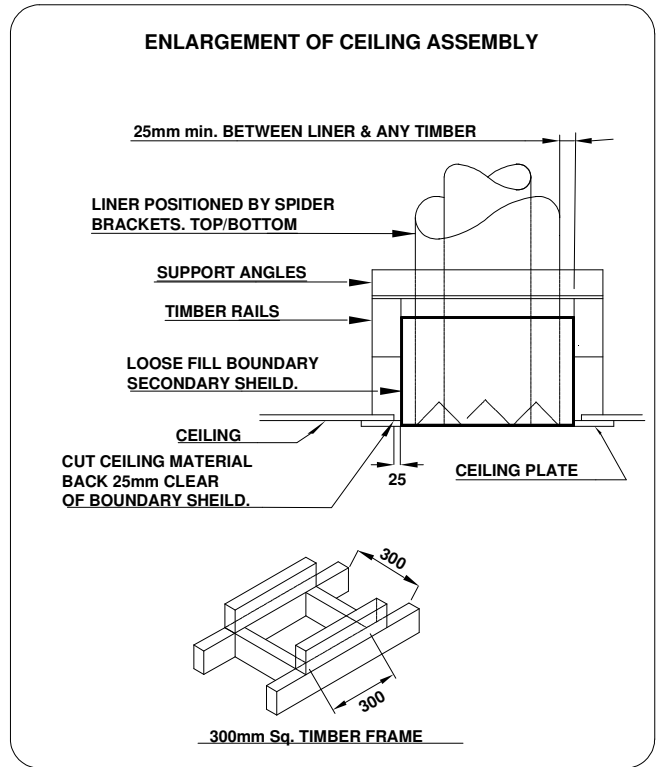

FIG B



CONDITIONS FOR FLUES (Refer Fig. E)

1. The FLUE shall extend to:
 Not less than 600mm above the highest point on the roof if within 3.0m of that point.
 Not less than 1000mm above the intersection point with the roof and not lower than any point of the roof within 3.0m.
 In any case the length of the flue shall not be less than 4.6m from the ash floor protector.
 In some situations the Local Council may vary the above requirements.
2. All parts of the chimney exposed to the outside air shall be suitably insulated in accordance with the manufacturers' recommendations.
 When loose- fill insulation is used in the adjacent ceiling space, maintain clearance between the secondary shield and the loose-fill insulation by provision of a boundary extending 200mm above the ceiling top surface.
 This non-combustible boundary shield shall be capable of preventing accidental migration of the loose-fill by any action of wind or by persons moving in the ceiling space.

Note: All Dimensions are in millimetres.

FIG C: HEATER DIMENSIONS – HOBSON (Drawings on this page not to scale)

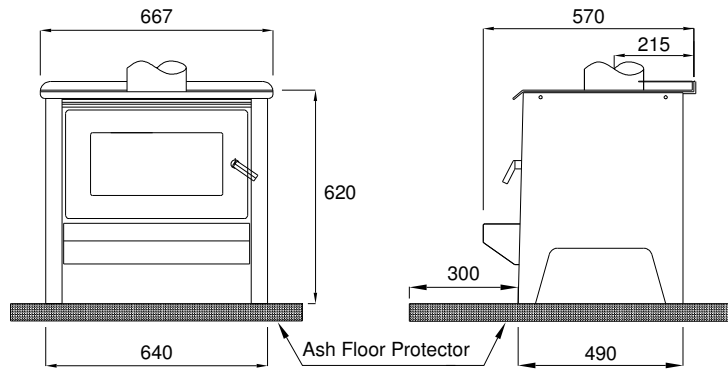
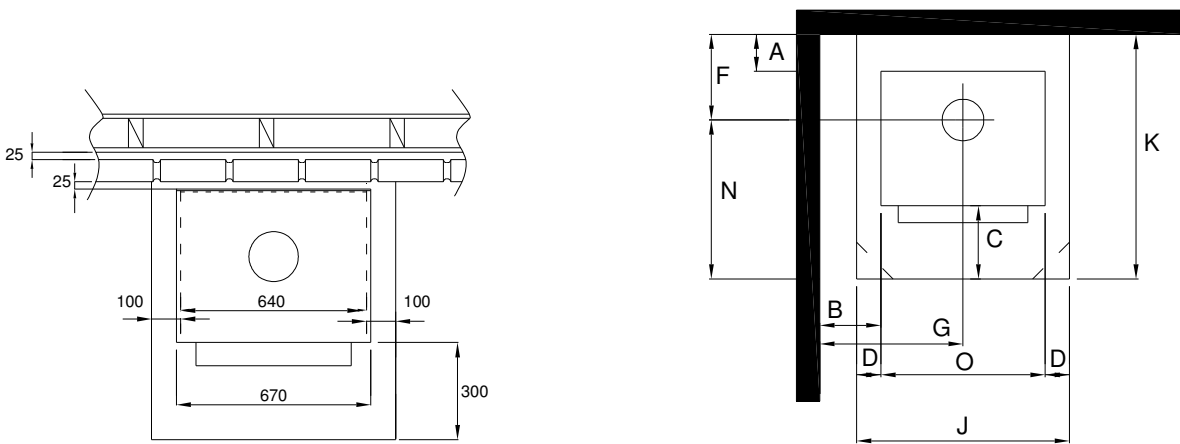

FIG D: HEATER POSITION. N.B. The “O” measurement on the Hobson measures the width of the heater, the cooktop surface slightly overhangs the sides.



Above: Non combustable wall clearances. Brick lining from floor to within 25mm of ceiling. Leave air vents at the bottom to allow airflow in the cavity. If Yunca flue mounted shield is fitted, brickwork may be 1200mm high as long as all vertical joints in top and bottom of brickwork are left out to allow airflow when brickwork is capped.

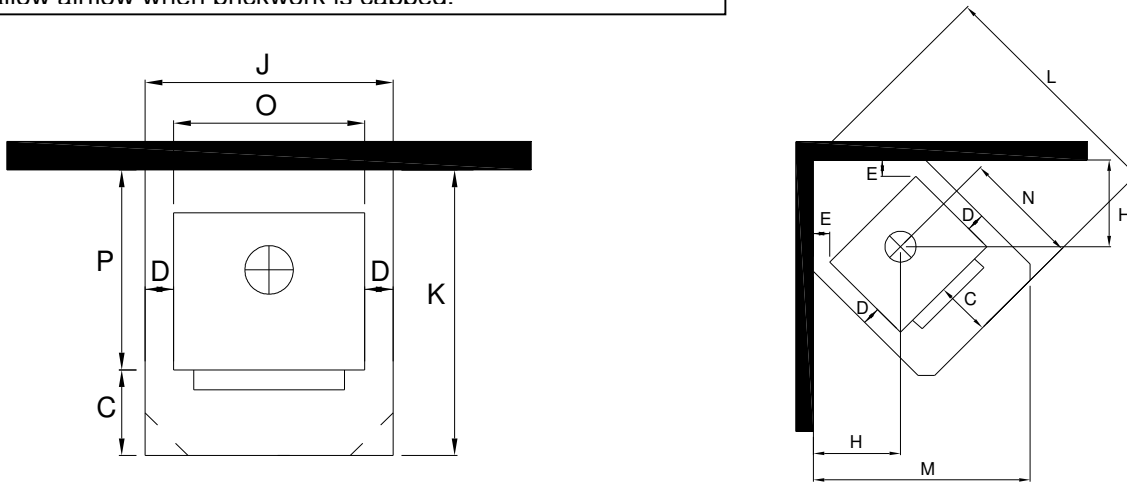

FIG D: MINIMUM FIRE TO COMBUSTABLE WALL CLEARANCES - HOBSON (WITH YUNCA FLUE MOUNTED SHIELD FITTED). Measurements in millimetres.

A	B	E	F	G	H
150	330	90	365	650	468

FIG D: MINIMUM FLOOR PROTECTION MEASUREMENTS (WITH YUNCA FLUE MOUNTED SHIELD FITTED). Measurements in millimetres.

C	D	J	K	L	M	N	O	P
300	100	840	940	1237	1160	575	640	640

FLUE SYSTEM REQUIREMENTS FIG. E

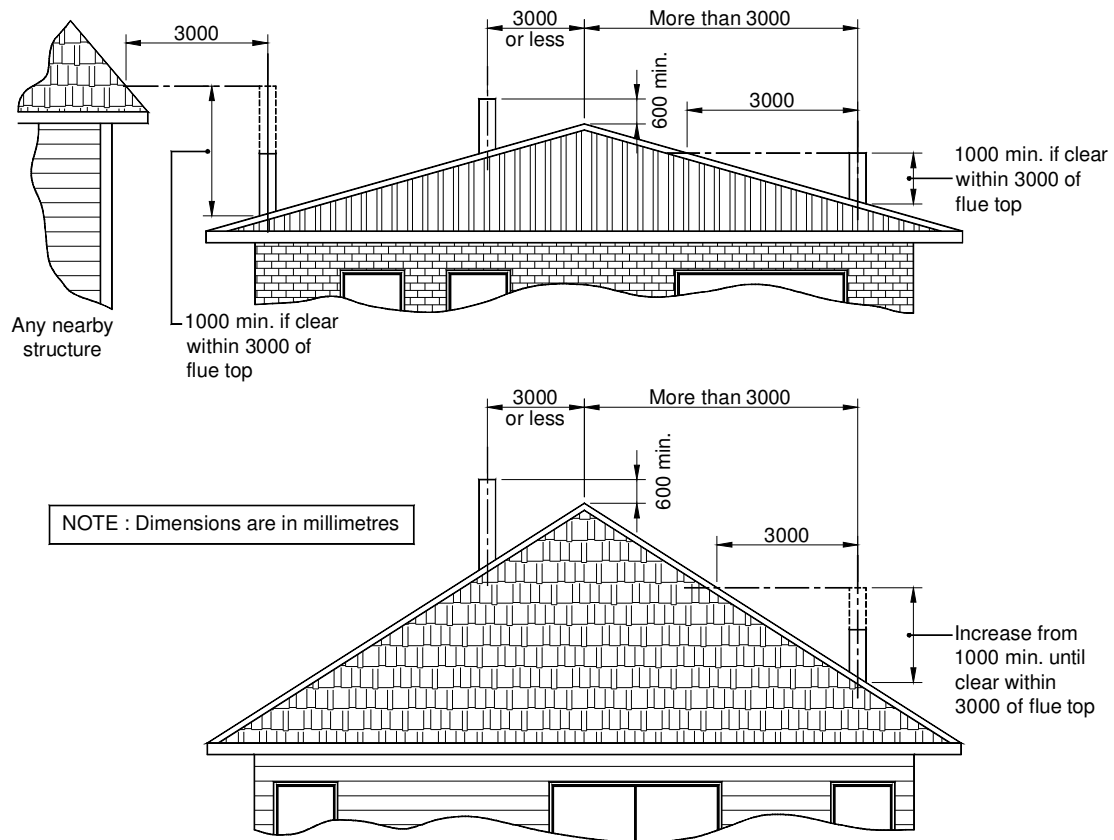

MINIMUM HEIGHT OF FLUE SYSTEM EXIT

IMPORTANT INFORMATION

- A. The appliance and flue system shall be installed in compliance with AS/NZS 2918 and the appropriate requirements of the relevant building code or codes.
- B. Appliances installed in accordance with this standard shall comply with the requirements of AS/NZS 4013 where required by the regulatory authority i.e. the appliance shall be identifiable by a compliance plate with the marking "TESTED TO AS/NZS 4013"
- C. Any modification of the appliance that has not been approved in writing by the testing authority is considered to be in breach of the approval granted for compliance with AS/NZS 4013
- D. Mixing of appliance or flue system components from different sources or modifying the dimensional specification of components may result in hazardous conditions. Where such action is considered, the manufacturer should be consulted in the first instance.
- E. Cracked and broken components e.g. glass panels or fire bricks, may render the installation unsafe.

IF THE A WATERBOOSTER IS FITTED:

Note: A water booster cannot be fitted to the Sub 1.0 Clean Air model Hobson

- A. Do not connect to an unvented hot water system
- B. Install in accordance with AS 3500.4.1 or NZS 4603 and the appropriate requirements of the relevant building codes.

Seismic Restraint

Secure the heater base to the hearth or sub-framing with dynabolts or similar through the holes provided. Follow local Council's Specifications.