



# Installation and Operating Instructions for the following Woodsmen models

These instructions should be read in conjunction with the flue installation instructions and drawings supplied with each HHF HeatSaver flue system.

## Testing and Certification

MODEL	AS/NZS 2918:2001	AS/NZ 2918:2001, APP E	AS/NZS 4012:1999	AS/NZS 4013:1999	ECan Cert Number
Blaze	Complies	N/A	66%	0.7g/kg	082947
Boston	Complies	N/A	67%	0.8g/kg	073734
Matai DVI-165	Complies	Complies	67%	0.53g/kg	04002/3
Matai ECR MkII	Complies	N/A	>65%	<1.0g/kg	071128
IMF	Complies	Complies	70% (est)	3.9g/kg	-
Manhattan	Complies	N/A	67%	0.8g/kg	073735
Milford	Complies	N/A	Not tested	Not tested	-
RMF	Complies	N/A	83%	3.9g/kg	-
RMF - RV	Complies	Complies	70% (est)	3.9g/kg	-
Regent	Complies	Complies	69%	0.9g/kg	072526
Strongman	Complies	N/A	Not tested	Not tested	-
Tarras	Complies	N/A	70%	0.88g/kg	094113
Tarras - WB	Complies	N/A	65%	0.99g/kg	094114



**KEEP THESE INSTRUCTIONS FOR FUTURE REFERENCE**

# Minimum Safe Installation Clearances

FIG 1

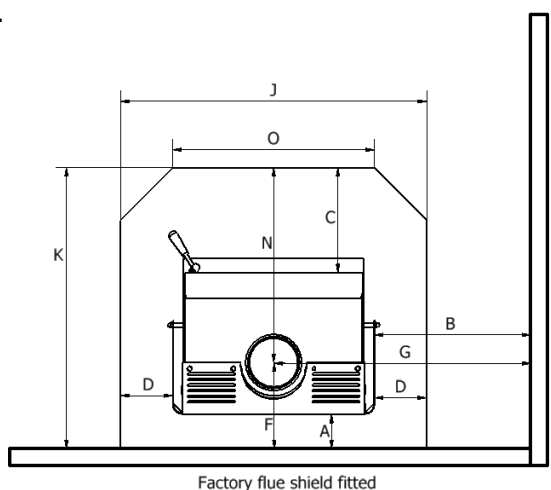
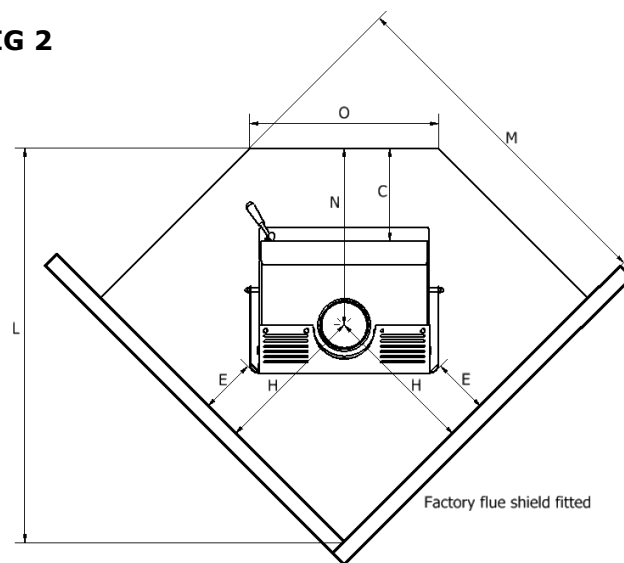

FIG 2



	BLAZE	ECR MkII	MANHATTAN & BOSTON	MILFORD	RMF	RMF - RV	STRONGMAN	TARRAS & TARRAS-WB
<b>A</b>	200	100	150	210	125	N/A	300	160
<b>B</b>	250	450	300	285	500	500	*875	550
<b>C</b>	300	300	300	300	300	300	515	500
<b>D</b>	150	150	150	150	150	150	150	150
<b>E</b>	100	200	140	100	180	N/A	380	300
<b>F</b>	371	251	318	381	276	N/A	441	301
<b>G</b>	560	740	610	628	790	790	**1233	906
<b>H</b>	421	512	459	446	492	N/A	711	626
<b>J</b>	920	880	920	986	880	880	1015	1015
<b>K</b>	1038	807	986	1054	832	N/A	1364	1184
<b>L</b>	1264	1280	1318	1303	1252	N/A	1928	1769
<b>M</b>	1113	1110	1151	1164	1060	N/A	1616	1493
<b>N</b>	669	556	668	673	556	N/A	923	883
<b>O</b>	620	580	620	686	580	580	715	686

Table 1

All dimensions are given in millimetres .

\*610mm with firebox side panels fitted.

\*\*968mm with firebox side panels fitted.

# Minimum Safe Installation Clearances

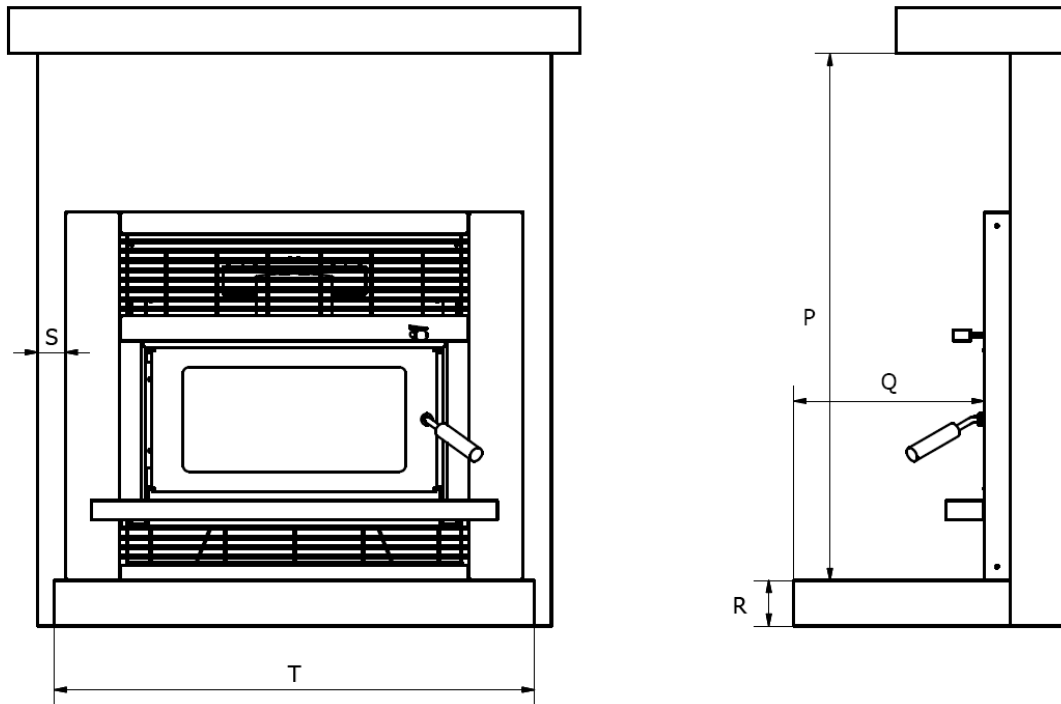

	<b>DVI-165</b>	<b>IMF</b>	<b>REGENT</b>	<b>RMF-RV</b>
<b>P</b>	930	980	923	913
<b>Q<sup>1</sup></b>	380	460	333	300
<b>R<sup>1</sup></b>	0	0	0	12
<b>Q<sup>2</sup></b>	352	408	309	-
<b>R<sup>2</sup></b>	13	25	13	-
<b>Q<sup>3</sup></b>	325	363	300	-
<b>R<sup>3</sup></b>	25	50	>18	-
<b>Q<sup>4</sup></b>	300	300	-	-
<b>R<sup>4</sup></b>	40	88	-	-
<b>S</b>	50	50	50	-
<b>T</b>	840	840	840	880

Table 2

\* If Q = Q<sup>1</sup>; then R = R<sup>1</sup> etc.

# Installation Instructions

**This appliance should only be installed by a trained and qualified installer.**

**Warning:** the appliance and flue system shall be installed in accordance with AS/NZS 2918 and the appropriate requirements of relevant building code/codes.

**Warning:** appliances installed in accordance with this standard shall comply with the requirements of AS/NZS 4013 where required by the regulatory authority, i.e. the appliance shall be identifiable by a compliance plate with the marking "Tested to AS/NZS 4013".

Any modification of the appliance that has not been approved in writing by the testing authority is considered to be in breach of the approval granted for compliance with AS/NZS 4013.

**Caution:** mixing of appliance or flue system components from different sources or modifying the dimensional specification of components may result in hazardous conditions. Where such action is considered, the manufacturer should be consulted in the first instance.

**Caution:** cracked and broken components e.g. glass panels or ceramic tiles, may render the installation unsafe.

**Warning:** do not connect to an unvented hot water system.

Install in accordance with AS 3500.4.1 or NZS 4603 and the appropriate requirements of the relevant building code/codes.

- Maintain a clearance of at least 1 metre between front of the appliance and building structure or any other substantial immovable object.
- If the appliance is installed on a heat sensitive floor, the floor should be protected with an insulation floor protector, which shall extend entirely beneath the heater. For the correct floor protector extension, refer to dimension C in FIG 1 & 2.
- Your appliance shall be seismically restrained, including the floor protector, using the two metal seismic restraint brackets supplied.

## Minimum Material Specifications For Floor Protectors

MODEL	SPECIFICATION
BLAZE	8mm of ceramic tiles
ECR MkII	8mm of ceramic tiles
MANHATTEN & BOSTON	8mm of ceramic tiles
MILFORD	12mm HardiFlex
RMF (2006+)	8mm of ceramic tiles
RMF - RV	12mm Hardiflex
STRONGMAN	24mm Eterpan
TARRAS & TARRAS-WB	24mm Eterpan

# Minimum Flue Height

The top of the flue system should be at least 600mm above the highest point of the roof ridgeline, if the point of intersection of the flue system and the roofline is less than 3 metres from the ridgeline horizontally.

If the point of intersection of the flue system and the roofline is greater than 3 metres horizontally, the top of the flue system shall be at least 1 metre above the point of intersection with the roofline. (refer FIG 3)

FIG 3.

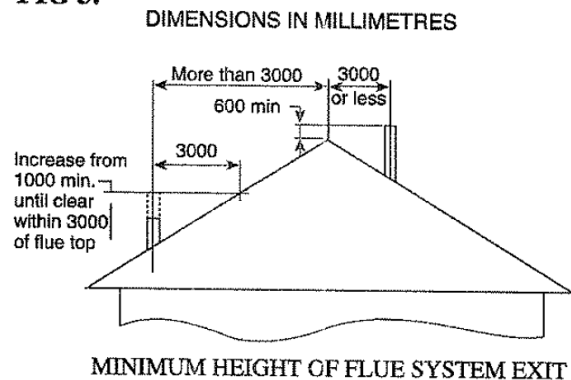

These are considered to be **minimum dimensions**, and depending on local conditions, **taller flue system heights may be required for satisfactory performance.**

## Flue Installation Detail

Your Woodsman appliance should be installed with a HeatSaver Flue System.

A HeatSaver Flue System is available from all authorised Woodsman dealers throughout New Zealand.

The HeatSaver Flue System contains a complete installation drawing and correct clearances from the ceiling level up. Minimum clearances from the appliance to nearby combustible surfaces are given in FIGS 1 & 2.

Use of a flue system other than a genuine HeatSaver Flue System may affect the safety of the installation, and may affect your Woodsman 10 year warranty.

**Insist on a genuine HeatSaver Flue System.**

**Installation requirements for Woodsman fireplace inserts and flue system where timber framing is less than 50mm from the chimney structure.**

Installation should be carried out by a qualified installer who will ensure:

- That the minimum clearances determined by tests in accordance with AS/NZS 2918:2001 are complied with to prevent overheating of nearby combustibles.
- That the minimum opening size of **600mm wide x 600mm high x 500mm deep** is available when firebricks are removed, and that extra provision also be made for plumbing where a hot water booster is fitted (where permitted).
- That any flue requirements specific to the model being installed are met in full - refer HeatSaver Flue System Instructions.
- Where the fireplace opening is in a heat sensitive wall, a non-metallic heat resistant material shall extend not less than 50mm beyond each side of the appliance and 150mm beyond the top of the appliance.
- Clearance of at least 1 metre between the front of the appliance and building structure, or any other substantial material object.
- That the insulating floor protector of non-combustible material is provided, extending not less than the dimensions shown in the chart. (Refer Table 2)
- A fireplace appliance shall not be connected to a flue common with an open fireplace.

# Operating Instructions (Burning Wood)

## Keep these instructions for future reference

**Important:** ensure installation instructions have been adhered to before lighting the appliance.

**Important:** firewood should be loaded in a front to back direction when operating this appliance.

**Warning:** any modification of the appliance that has not been approved in writing by the testing authority is considered as breaching AS/NZS 4013.

**Warning:** do not use flammable liquids or aerosols to start or rekindle the fire.

**Warning:** do not use flammable liquids or aerosols in the vicinity of this appliance when it is operating.

**Warning:** do not store fuel within heater installation clearances.

For your comfort, it is advised that you light your first fire with the windows open to allow the escape of paint fumes. This will normally happen for the first 30 minutes of the first burn.

Fully open the heat control. Place wood kindling and paper or firelighter in the firebox. Ignite and leave the door partially open by resting on the catch until the fire is blazing (4-5 minutes), and burns well with the door closed. Do this only from a cold start. Once the fire is underway, adjust the heat control to suit. If the firebox or the flue becomes visible red-hot, adjust the heat control to a lower heat position to avoid being unnecessarily harsh on the unit as well as wasting excessive heat up the flue.

**Warning:** always open the heat control before opening the fire door.

For long holding operation in a Clean Air Zone, level the ashes and load with the firewood lying front to back, rather than left to right. After loading new wood, operate the fire with the heat control fully open for 20 minutes before closing the heat control to the lower burning position. By following this simple method of low burn firing, you will achieve very low emission rates and obtain the high efficiency burn that is associated with the Woodsman product.

The fuel approved for use in Clean Air Zones in this appliance is wood with a moisture content of less than 25% of dry weight. This usually means green timber left for at least three months to air dry.

**Caution:** the use of some types of preservative-treated wood as a fuel can be hazardous.

**Caution:** this appliance should not be operated with cracked glass.

**Caution:** this appliance should be maintained and operated at all times in accordance with these instructions.

# Operating Instructions (Multi-fuels)

Your Woodsman Multi-fuel will operate perfectly well burning coal, wood, briquettes or a mixture of any of these. Often the hottest temperatures are achieved by burning a mixture of wood with coal laid over the top.

The appliance has two heat controls. The High - Low control to the left of the ash pan door is for use when burning coal, briquettes, or a mixture of wood and coal. The High - Low control above the fire door is for use when burning wood only.

Set the fire using kindling wood and paper (or a solid fuel lighter), light and close the door; set the lower High - Low control on High and the upper High - Low control on Low. Once the fire is burning brightly, decide if wood or coal is to be used. If coal is to be burned, lay the coal over the burning fire and adjust to suit. If wood is to be burned, place dry logs on the fire and set the lower control to Low and the upper control to suit the required burning rate.

**Important:** Ensure the ash pan door is closed firmly before lighting, and remains so during use. **Do not** have both controls fully open at the same time. If burning wood, the lower control should be fully closed; if burning coal, the upper control should be set to Low.

If the ash pan door knob is removable, it should be removed while the stove is in use. This is a safety feature designed to avoid the ash pan door being opened by children in particular, and risking any overheating of nearby combustibles by the increased combustion rate.

## Creosote Formation

A small intense fire is preferable to a large smouldering one, to reduce the amount of creosote. When wood is burned slowly it produces tar and other organic vapours, which combine with expelled vapour to form creosote. These creosote vapours condense in the relatively cool flue of a slow burning fire. As a result, creosote residue accumulates on the flue. When ignited, this creosote makes an extremely hot fire.

The flue should be checked at least every 2 months, during the burning season, to determine if a creosote build up has occurred. If this is the case, it should be removed by a chimney sweep to reduce the risk of an unexpected flue fire.

Your appliance has been designed to produce low levels of creosote at high and low settings.

**In the event of a chimney fire, close the firebox door, fully close the heat control, vacate the premises and call the fire service.**

## Storage of Fuel

Do not store fuel within installation clearances or within the space required for refuelling or ash removal.

## Disposal of Ashes

Ashes should be placed in a metal container with a tight-fitting lid. The closed container of ashes should be placed on a non-combustible floor or on the ground well away from all combustible materials, pending final disposal once cooled.

**The door must be closed at all times during the operation, except during refuelling and occasional poking of the fire when necessary. Ensure door seals are maintained in good condition.**

**Your appliance and flue system should not be modified in any way without the approval of the manufacturer.**

Manufactured by W H Harris Ltd  
Trading as Harris Home Fires  
PO Box 4043  
41 Braddon Street  
Christchurch  
New Zealand





# 10 YEAR WARRANTY

This WOODSMAN fire is warranted for a period of 12 months to the original purchaser, from the date of purchase, against defects of manufacture. If a defect occurs, inform your dealer and the part will be repaired or replaced at our option.

This warranty does not cover damage caused by mishandling, misuse, failure to follow the manufacturer's installation and operating instructions, or work done by others such as installers, or plumbers etc.

Your WOODSMAN firebox is then covered by a further nine year warranty against defect during normal domestic use.

In the case of a claim after the first 12 months, it shall be the owner's responsibility and expense to deliver the WOODSMAN fire to the dealer from whom it was purchased, and the reinstallation after any repair has been made.

The manufacturer shall not be responsible for site conditions such as insufficient draught, downdraughts, or routine servicing and adjustments.

Exempted from any warranty are any door glass, firebox baffle, firebox air tube, grate and firebricks. Your high temperature paint finish is warranted for 12 months from date of purchase.

Any factory fitted water heating system is warranted against leakage for a period of 6 months from purchase.

Please complete this form following installation, attach your copy of the Sales Invoice and file securely. This form and Sales Invoice will be required to be sighted in the event of a warranty claim.

OWNER'S NAME: \_\_\_\_\_

ADDRESS: \_\_\_\_\_

\_\_\_\_\_

MODEL:
SERIAL NUMBER:

Date Purchased:    /    /
---------------------------

INSTALLED BY: \_\_\_\_\_

\_\_\_\_\_



41 BRADDON STREET, PO BOX 4043, CHRISTCHURCH, NEW ZEALAND  
Phone 03 366 1796, Fax 03 366 1795  
Email: sales@hhf.co.nz, Website: www.harrishomefires.co.nz

