

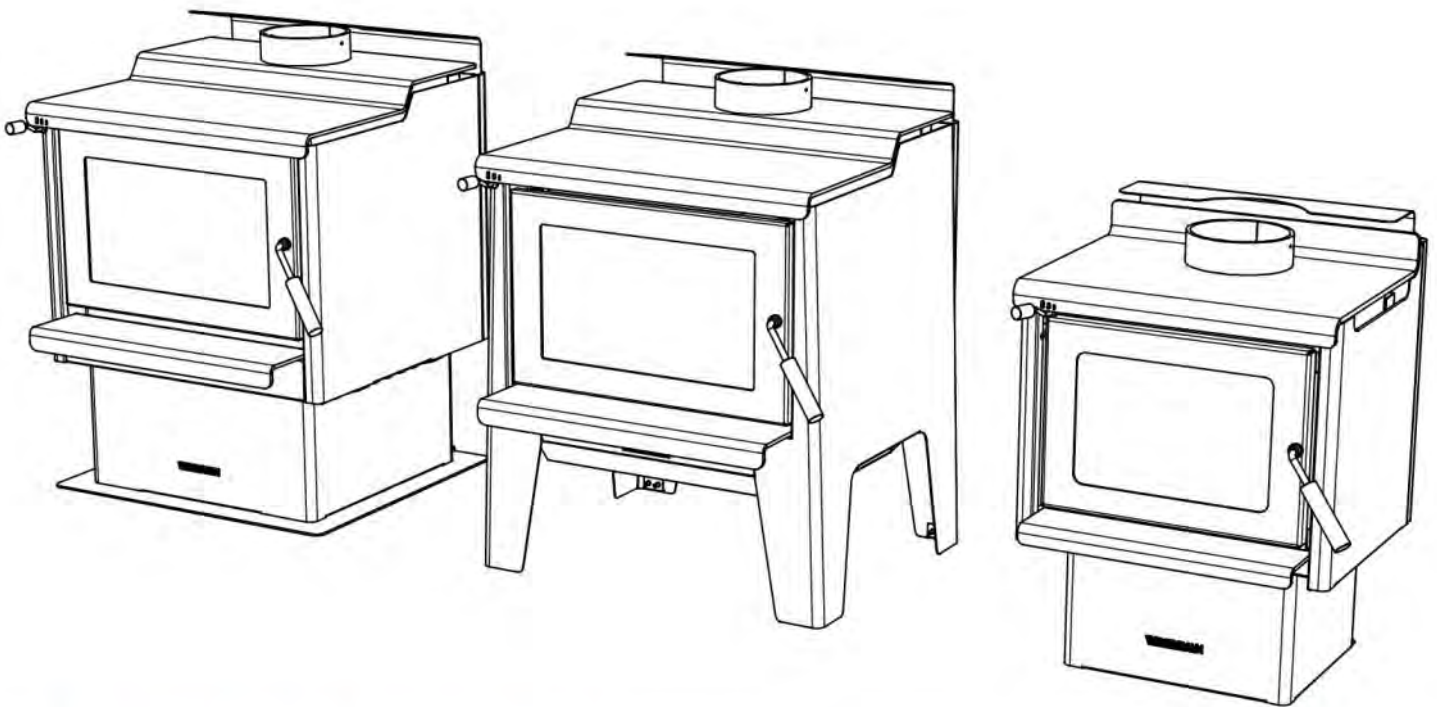

# WOODSMAN

## Specifications, Installation and Operating Instructions for the: Coleridge & Kanaku



### Ultra Low Emission Burners

**KEEP THESE INSTRUCTIONS FOR FUTURE REFERENCE**

Proudly Manufactured By:



Harris Home Fires  
41 Braddon St  
Addington  
Christchurch 8024  
New Zealand  
Email sales@hhf.co.nz

P O Box 4043  
Christchurch 8140  
New Zealand

**Phone** 03 366 1796  
**Freephone** 0800 3661796

# Testing and Certification

MODEL	AS/NZS 2918:2001	CM1.6 (ULEB)	AS/NZS 4012:2014	AS/NZS 4013:2014	Authorisation Number
Coleridge Ped	Complies	–	66.3%	0.49g/kg	211399
Coleridge Ped	Complies	28.6mg/MJ	–	–	211398
Coleridge Leg	Complies	–	66.3%	0.49g/kg	211474
Coleridge Leg	Complies	28.6mg/MJ	–	–	211473
Kanaku	Complies	–	74%	0.3g/kg	223217
Kanaku	Complies	34mg/MJ			223218

## Warnings

- Your appliance and flue system should not be modified in any way without the approval of the manufacturer.
- Any modification of the appliance that has not been approved in writing by the testing authority is considered as breaching the conditions of the certification and could be considered unsafe.
- This appliance is not intended for use by persons (including children) with reduced physical, sensory or mental capabilities, or lack of experience and knowledge, unless they have been given supervision or instruction concerning use of the appliance by a person responsible for their safety.
- Do not leave children un-attended near a fire and keep them well away from the fire when in use. Supervise young children to ensure that they do not play with the appliance.
- Do not use flammable liquids or aerosols to start or rekindle the fire. Also do not use or store such flammable materials in the vicinity of this appliance when it is operating.
- The use of some types of preservative-treated wood as a fuel can be hazardous and is prohibited.
- Always keep clothing, firewood, furnishing and other combustible materials at a safe distance from the fire.
- Do not touch any part of the fire other than the door handle and the air control when in use as all other parts can be extremely hot.
- Cracked/broken door glass, makes the installation unsafe. Do not operate the fire with cracked glass.
- Do not use the fire if there is a malfunction, a suspicion of breakage or unusual noises. Contact your nearest Woodsman dealer or Harris Home Fires.
- This appliance should be operated & maintained at all times as per instructions given in this manual.

Failure to follow above warnings, cautionary measures and instruction given in this installation and operation manual will void the warranty of this product.

## Before You Install

The installation of any solid fuel burner requires a Building Consent prior to installation commencing. We recommend the installation of a Woodsman solid fuel burner or flue system be undertaken by the holder of a current SFAIT (Solid Fuel Appliance Installation Technician) qualification issued by the NZHHA (NZ Home Heating Association Inc.).  
[www.nzhha.co.nz](http://www.nzhha.co.nz)

## Before Your First Light Up

- Ensure that your appliance has received a Code of Compliance from your local council building inspector.
- Ensure that your installer has sealed all the flue joints as per the installation instructions.
- Check to make sure that all the internal parts (bricks, baffles and air tubes) are properly in place and have not been moved during transit or installation.
- Be aware that when you first light the fire, there will be visible smoke that will come off the paint for approximately 30 to 60 minutes. This is quite normal and is the paint going through the final baking on process. The fire should be fully loaded with wood and run at the high setting for this time. We recommend that you light your fire at a suitable time of day where the area can be ventilated by opening doors and windows and disable any smoke alarms that may be affected.
- Read the lighting instructions in this document.

## Before You Use

It's important to note that modern clean air wood burners are different from older, non clean air approved burners. They operate differently and have different levels of maintenance. It is important to understand these differences to ensure that your fire operates efficiently, hassle free and you are doing your part to keep the air clean.

- Lighting your fire properly is important to ensure that the rest of the burn is clean and efficient.
- Your clean air approved burner has some consumable parts that your old fire probably didn't have.
- What type of wood you burn, its quality and how you burn it has a big impact on burn efficiency, air quality and the life of the consumable parts.

Please have a careful read of the rest of this manual to familiarise yourself with the best practises for using, maintaining and enjoying your Woodsman fire.

**It's also important to be aware that a wood stove is a hands on and practical appliance. It requires user maintenance on a regular basis and you need to be prepared to perform the tasks listed in the guide. If you are not able or confident in performing these tasks, please contact a service agent.**

# Dimensions: Coleridge

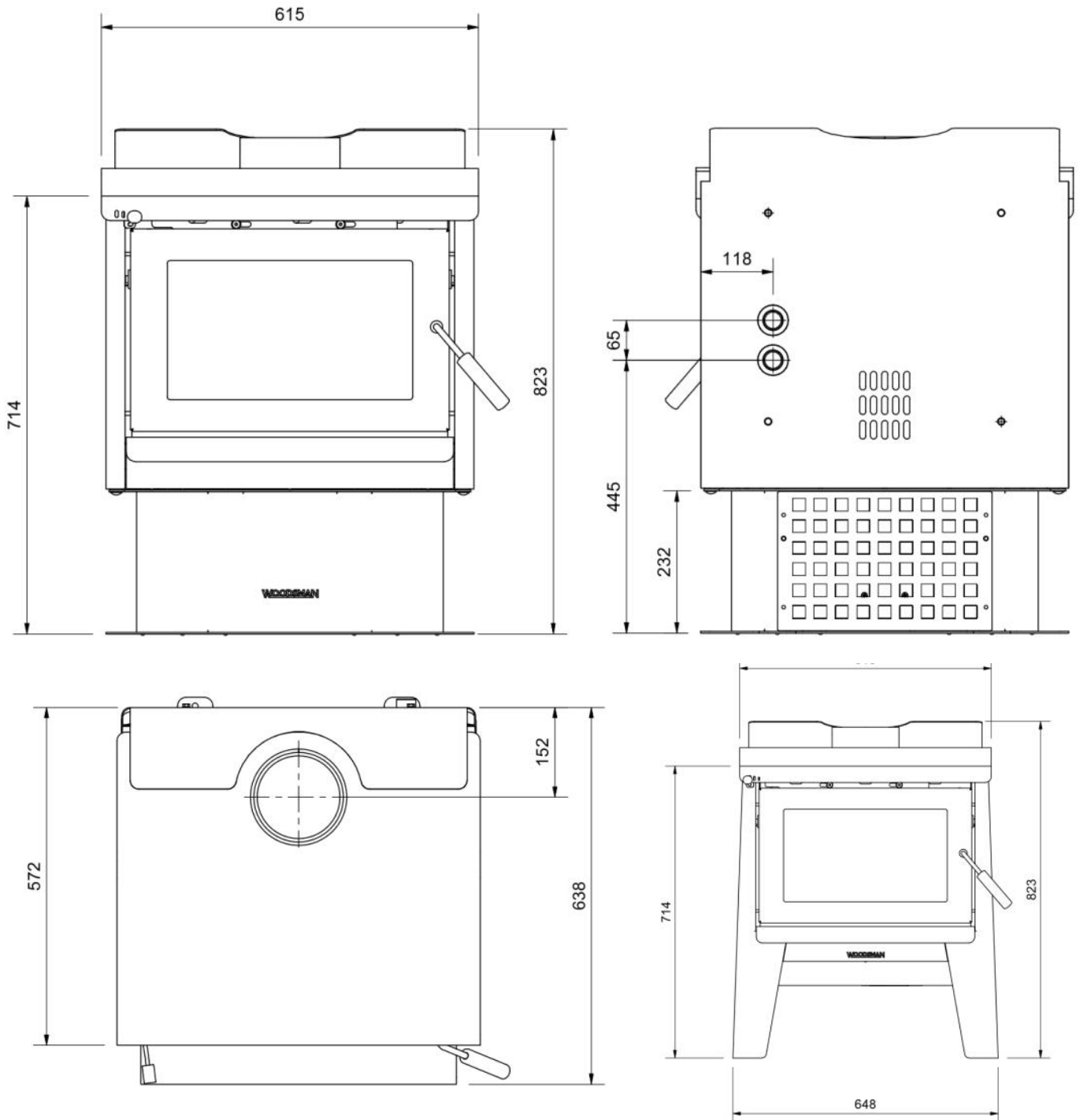

# Dimensions: Kanakanu

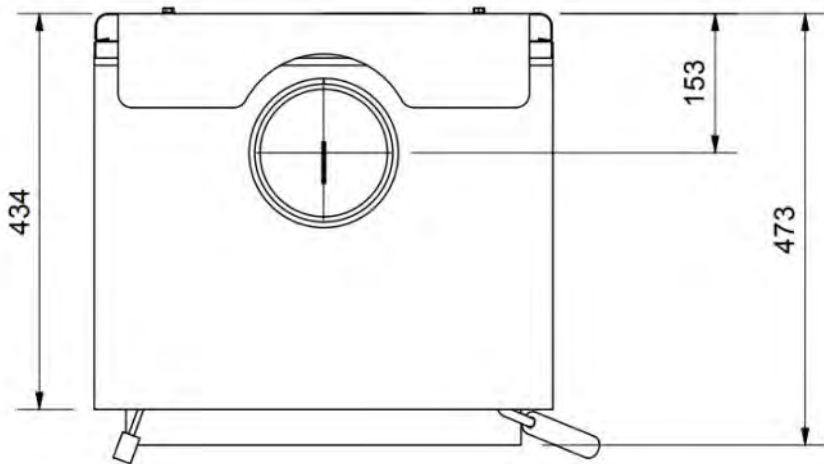
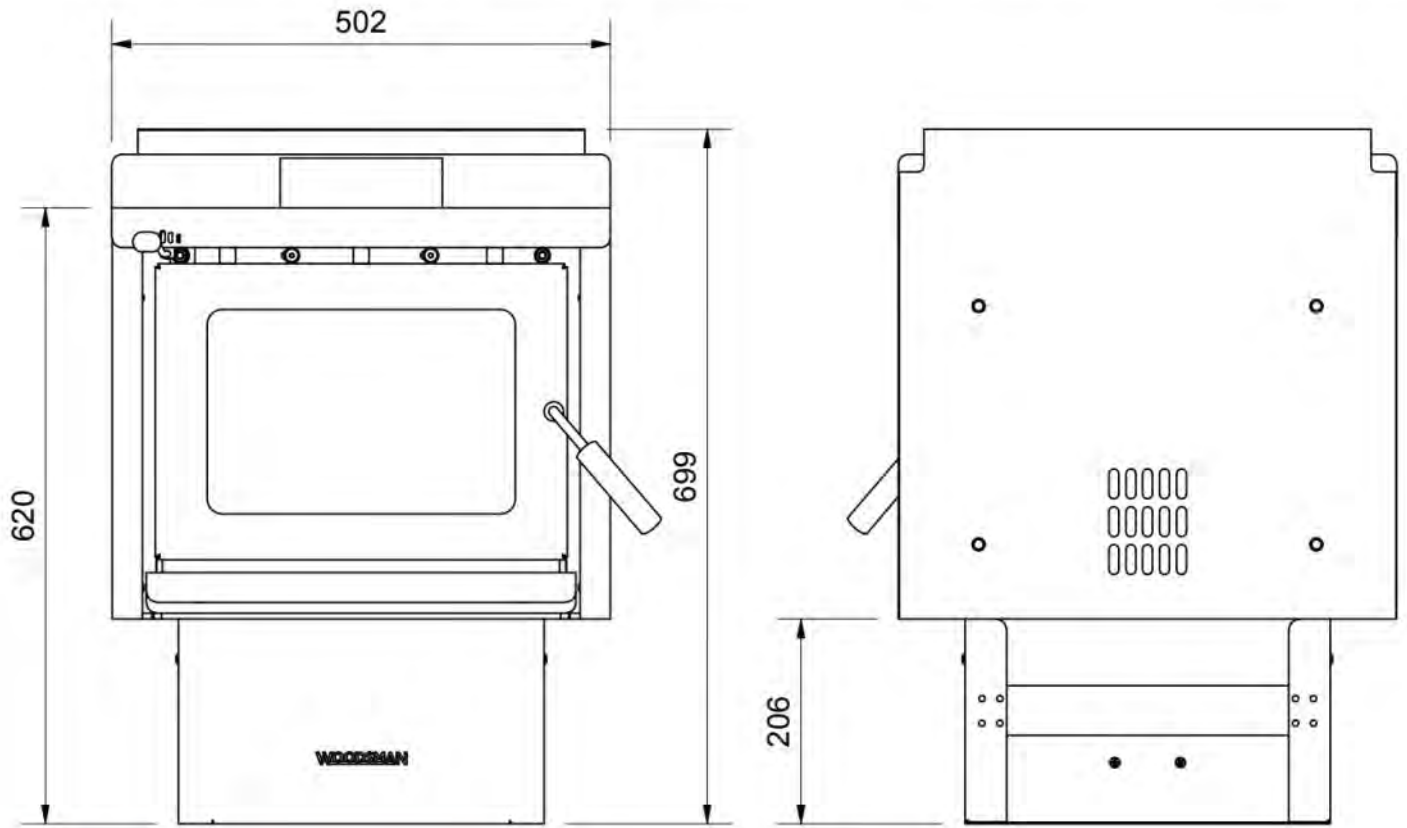

# COLERIDGE Minimum Safe Installation Clearances to COMBUSTIBLE Materials

As tested to AS/NZS 2918:2001 by Spectrum Laboratories, Test report number 0583

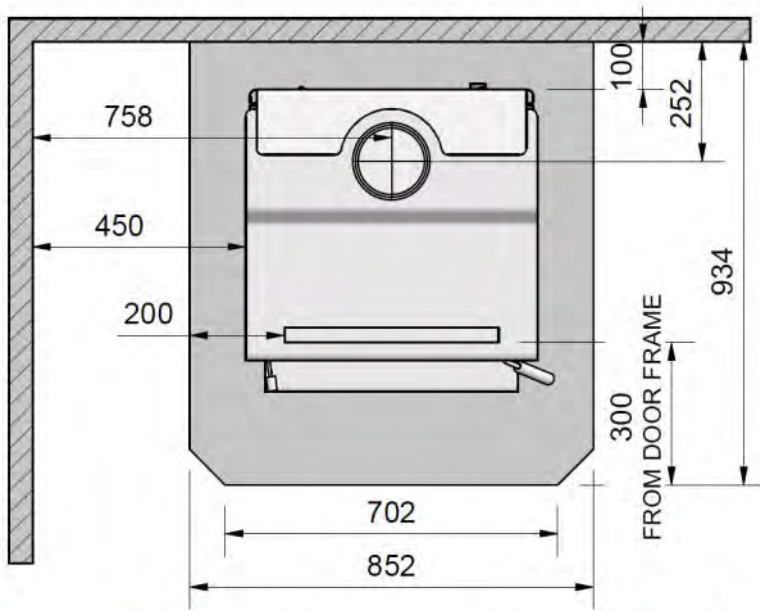

## Technical Requirements

### **Floor protector:**

Ash Hearth, any non-combustible material of any thickness

### **Flue Shield:**

1200mm high with flue deflector fitted

## Flue Shield Deflector

### **WARNING**

This part is required to be installed on the Coleridge with ALL types of flue kits. Failure to do so, may cause the ceiling to over heat. The part is located in the fire itself and not the flue kit packaging.

### **To fit the heat shield deflector:**

- Place the deflector on top of the heat shield and ensure no large gaps
- Fix in place by securing the tabs with rivets to the heat shield

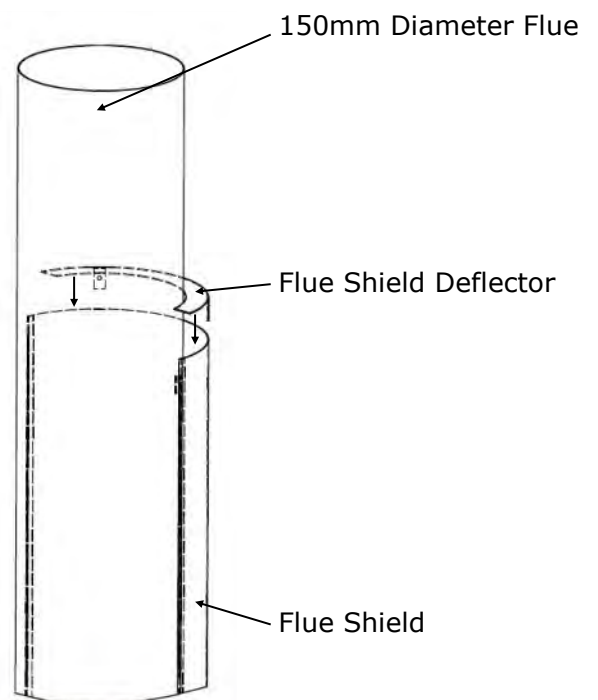
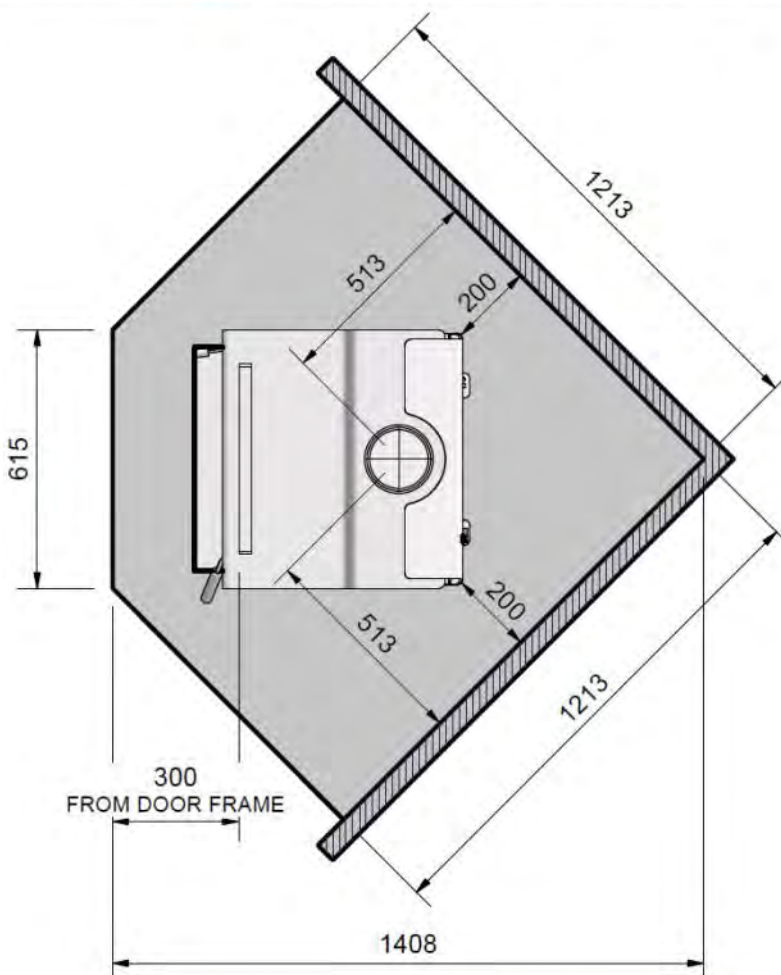

# KANAKU

## Minimum Safe Installation Clearances to COMBUSTIBLE Materials

As tested to AS/NZS 2918:2001 by Applied Research Services, Test report number 21/3090

### Technical Requirements

**Floor protector:**

Ash Hearth, any non-combustible material of any thickness

**Flue Shield:**

1200mm high

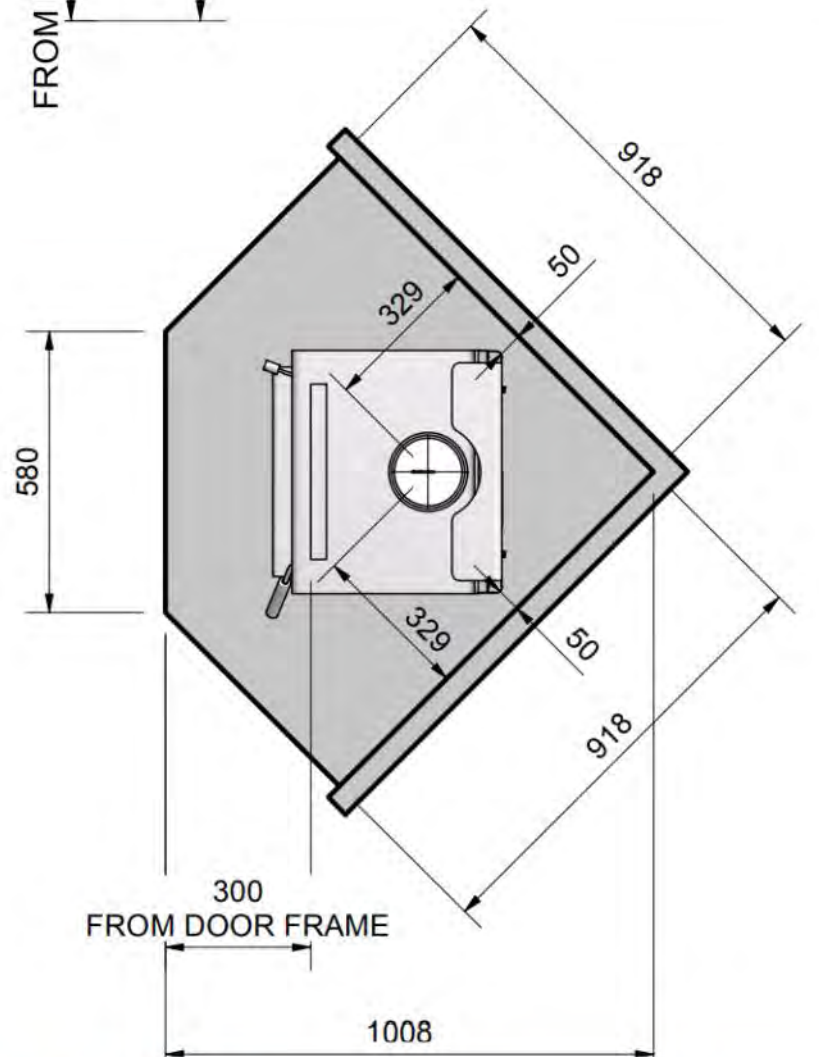
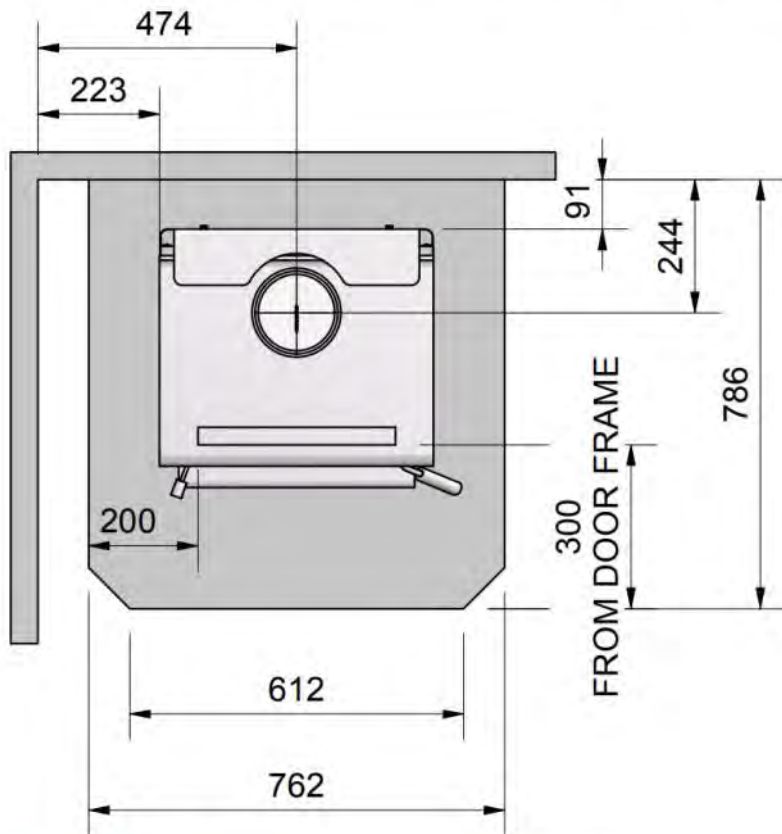

# Ceiling Heights

All Woodsman free standing fires have been tested and approved to AS/NZ 2918:2001 App B with a ceiling height of 2.4m and with the factory flue shield fitted in the below configurations. In some cases, the top of the flue shield terminates within 600mm of the ceiling height (refer to AS/NZ 2918:2001 **4.5.2**) but all ceiling temperatures did not exceed the allowable limit in these cases and are therefore able to be installed. Reports are available on request for Councils.

If the ceiling height is less than 2.4m, then heat shielding is required as per AS/NZ 2918:2001 Table 3.2

# Sealing Flue Joins

## **IMPORTANT**

**All Flue Joins Are Required To Be Sealed Using Flue Cement**

It is extremely important that ALL flue joins are sealed at the time of installation using flue cement or a suitable exhaust cement.

If flue joins are not sealed properly, it can lead to performance issues with the fire such as;

- Lower heat output of the fire, due to decreased performance
- Blocked flue
- Smoke coming out the door when open, due to decreased suction
- Hard to light

The formation of soot and creosote will not seal the flues, especially on the lower lengths, as the high temperatures inhibit its formation.

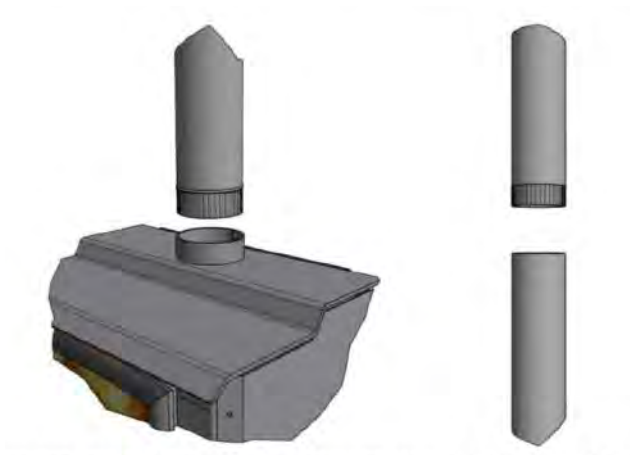

Any issues that arise as a result of the flues not being sealed, are not covered by the warranty and are not the responsibility of the manufacturer.

It is the installer's responsibility to ensure that this is done at the time of installation.

# Installation Instructions

**We recommend this appliance be installed by a trained and NZHHA qualified installer.**

**Warning:** the appliance and flue system shall be installed in accordance with AS/NZS 2918:2001 and the appropriate requirements of relevant building code/codes.

**Warning:** appliances installed in accordance with this standard shall comply with the requirements of CM1.6 where required by the regulatory authority, i.e. the appliance shall be identifiable by a compliance plate with the marking "Tested to CM1.6".

**Caution:** mixing of appliance or flue system components from different sources or modifying the dimensional specification of components may result in hazardous conditions. Where such action is considered, the manufacturer should be consulted in the first instance.

**Caution:** cracked and broken components e.g. glass panels or ceramic tiles, may render the installation unsafe.

- Maintain a clearance of at least 1 metre between front of the appliance and building structure or any other substantial immovable object.
- Your appliance shall be seismically restrained, including the floor protector using the provided holes or brackets. The restraints should be sufficient enough to resist a seismic loading equal to 0.4 times the mass of the appliance. We recommend a minimum of 8mm dynabolts on concrete floors and 8mm coach screws for wooden floors, of appropriate length.

## Minimum Flue Height

The top of the flue system should be at least 600mm above the highest point of the roof ridge, if the point of intersection of the flue system and the roofline is less than 3 metres from the ridge horizontally.

If the point of intersection of the flue system and the roofline is greater than 3 metres horizontally, the top of the flue system shall be at least 1 metre above the point of intersection with the roofline. (refer FIG 3)

**FIG 3.**

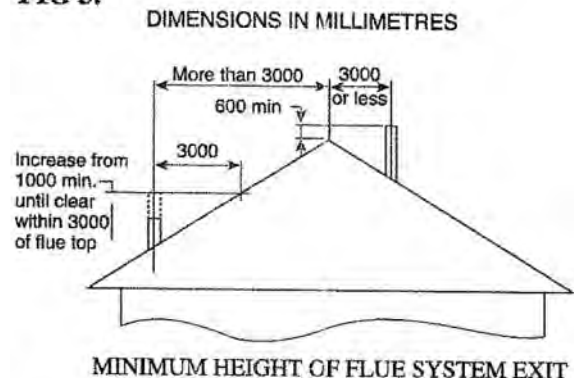

These are considered to be **minimum dimensions**, and depending on local conditions, **taller flue system heights may be required for satisfactory performance. The total flue height should be no less than 4.6m from the level of the floor protector.**

## Flue Installation Detail

Your Woodsman appliance should be installed with a HeatSaver Flue System.

A HeatSaver Flue System is available from all authorised Woodsman dealers throughout New Zealand.

Use of a flue system other than a genuine HeatSaver Flue System may affect the safety of the installation, and may affect your warranty.

**Insist on a genuine HeatSaver Flue System.**

# HeatSaver Flue Kit Installation



## INSTALLATION INSTRUCTIONS

- This HeatSaver flue system is tested and certified to AS/NZS 2918:2001 Appendix F, which means it is approved for use on all solid fuel appliances with a flue diameter of 150mm.
- A copy of the Laboratory Test Certificate for this HeatSaver Flue System is included as part of these Installation Instructions, (refer to paperwork with flue kit).
- Installation of any solid fuel appliance should only be carried out by suitably trained and qualified personnel.
- Position the stove to the desired position, always ensuring that the manufacturer's minimum clearances to combustibles are complied with.
- Check that there are no roofline ridges or valleys in the way, or if they cannot be avoided, that the installer knows how to weatherproof the penetration and reinstate the full strength of the structure.
- At the ceiling level, construct a square frame of 300mm x 300mm internal dimensions and cut away the ceiling materials from the inside of this frame.
- Lower the 300mm flue pipe casing into this frame and nail in place when the bottom edge is 25mm below the ceiling level and the 8 nail holes provided are touching the timber frame.
- Check all 4 locating brackets are securely in place and drop 250mm diameter lower casing in place. This will naturally settle so it protrudes 25mm below the ceiling.
- Make roof penetration, assemble and fit required flue length and install with upper casing. Secure all joints with at least 3 stainless steel rivets or self tapping screws.
- Frame and brace upper installation as required and flash the roof to shield penetration.
- Fit ceiling plate to ceiling.
- When trimming the stainless steel flue length, ensure the flue is flush with the casing at the top. If it is higher than the casing, the cowl can not be fitted correctly.
- Fix the bottom section of the HeatSaver Columbia Cowl in place and ensure that it is firmly down on top of the casing. Then attach top section by bending tab away from the shaft to allow the top section to slide down onto the washer. Bend tab back in place once done. Do not over bend tab so that it touched the shaft. See page 6
- Secure the flue to the fire, drill through flue neck on fire and secure with 2 to 3 s/s screws or rivets.
- All flue joints should be sealed using a flue cement.
- Ensure a 25mm clearance from the 250mm diameter casing to any combustible material.

# HEAT SAVER II FLUE KIT

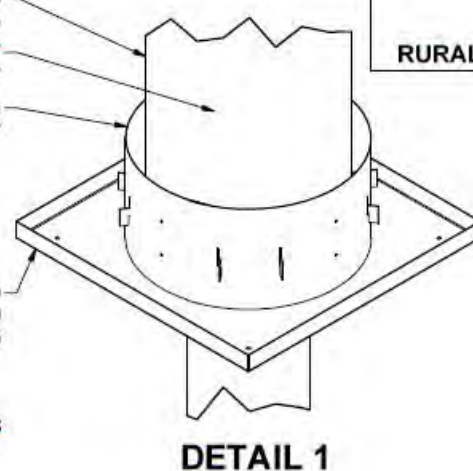
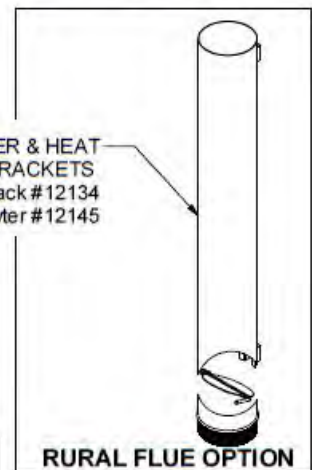
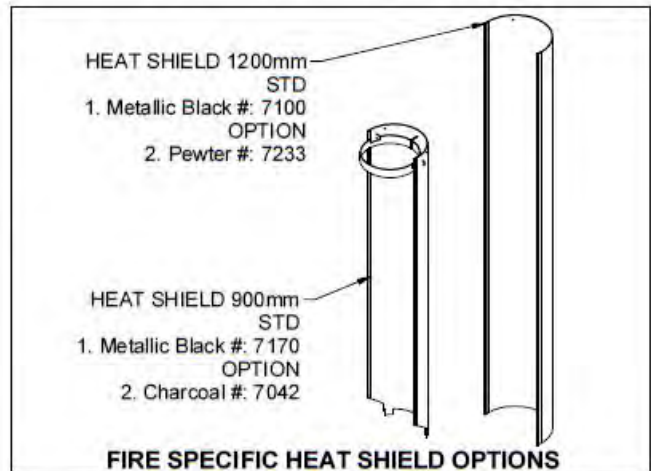
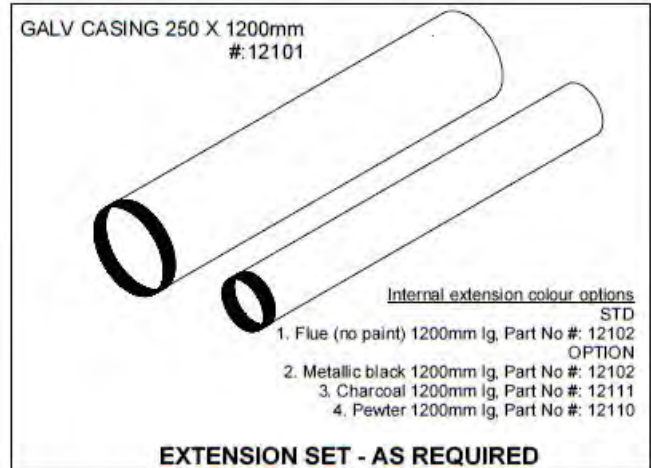
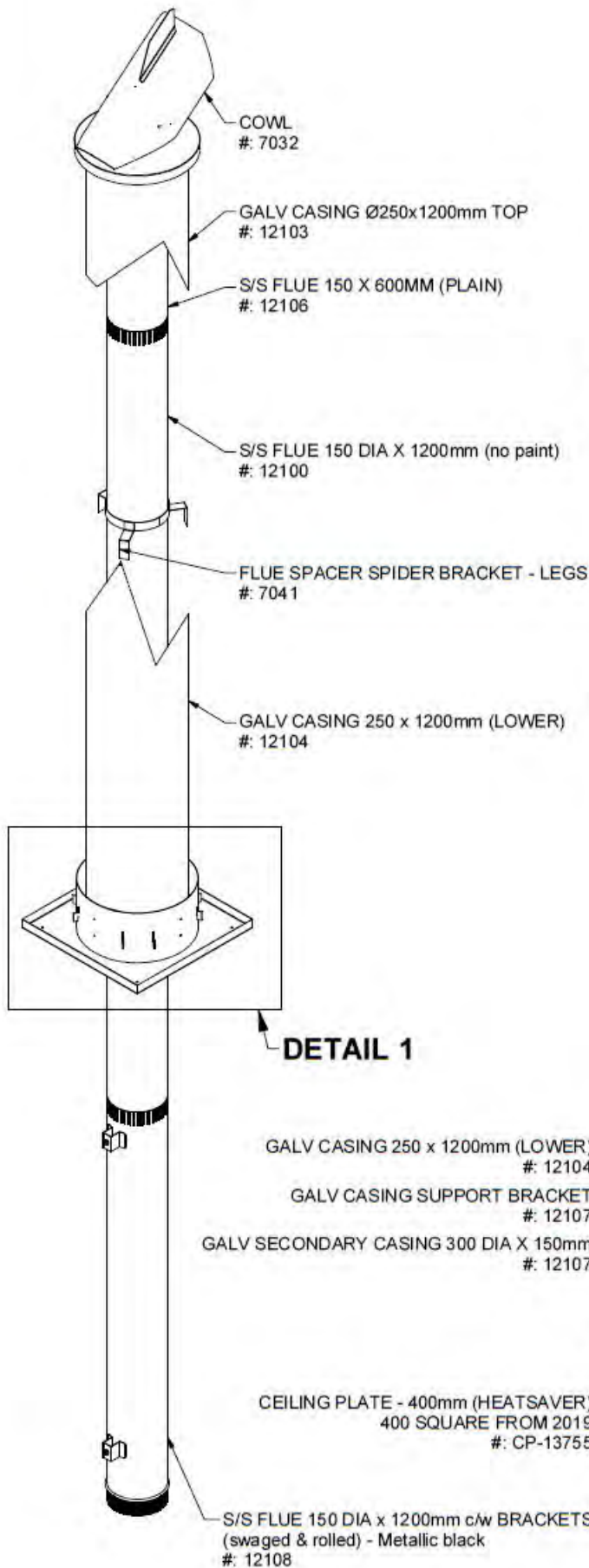

# Standard Ceiling

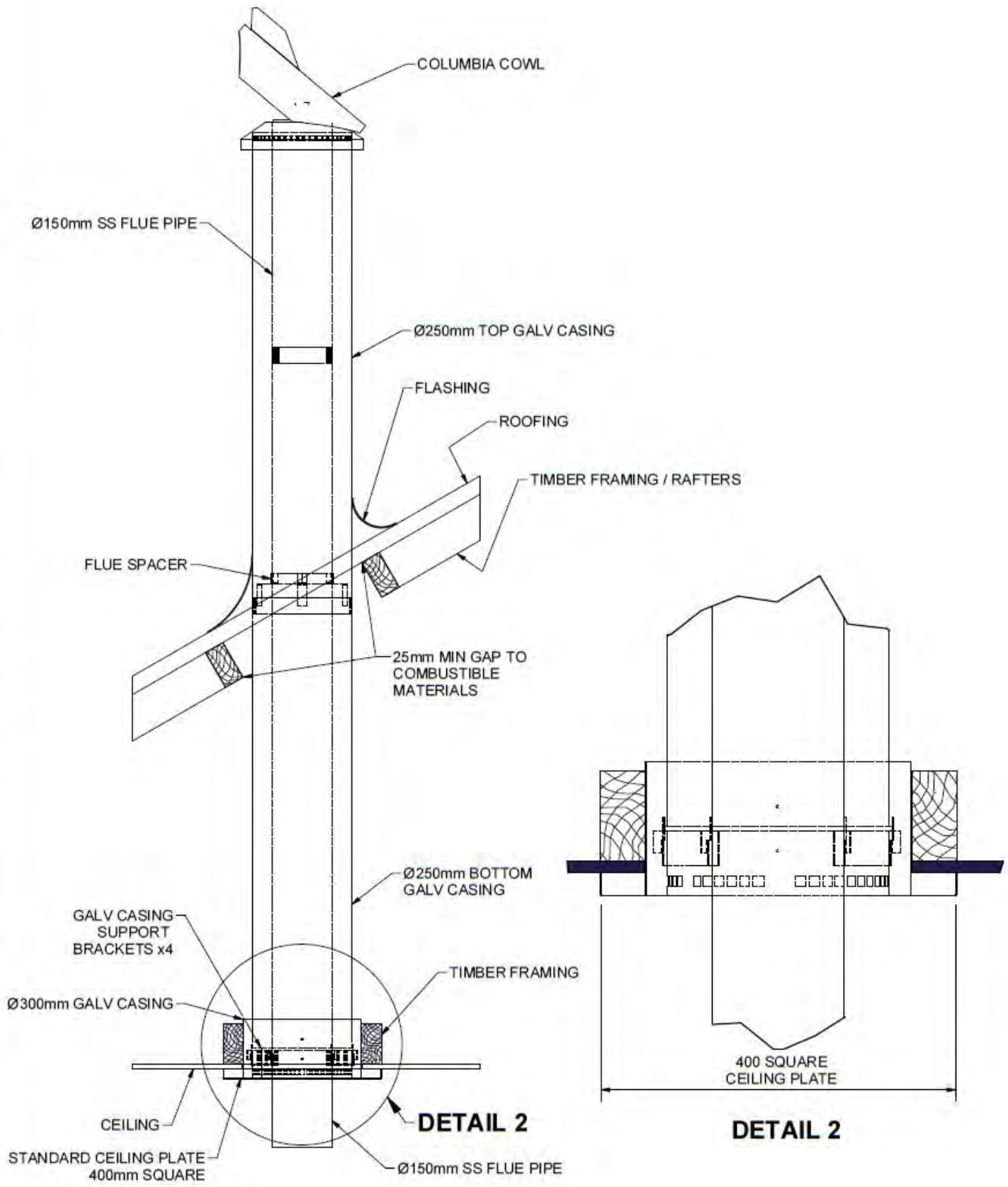

# No Cavity (Requires Sloping Ceiling Kit)

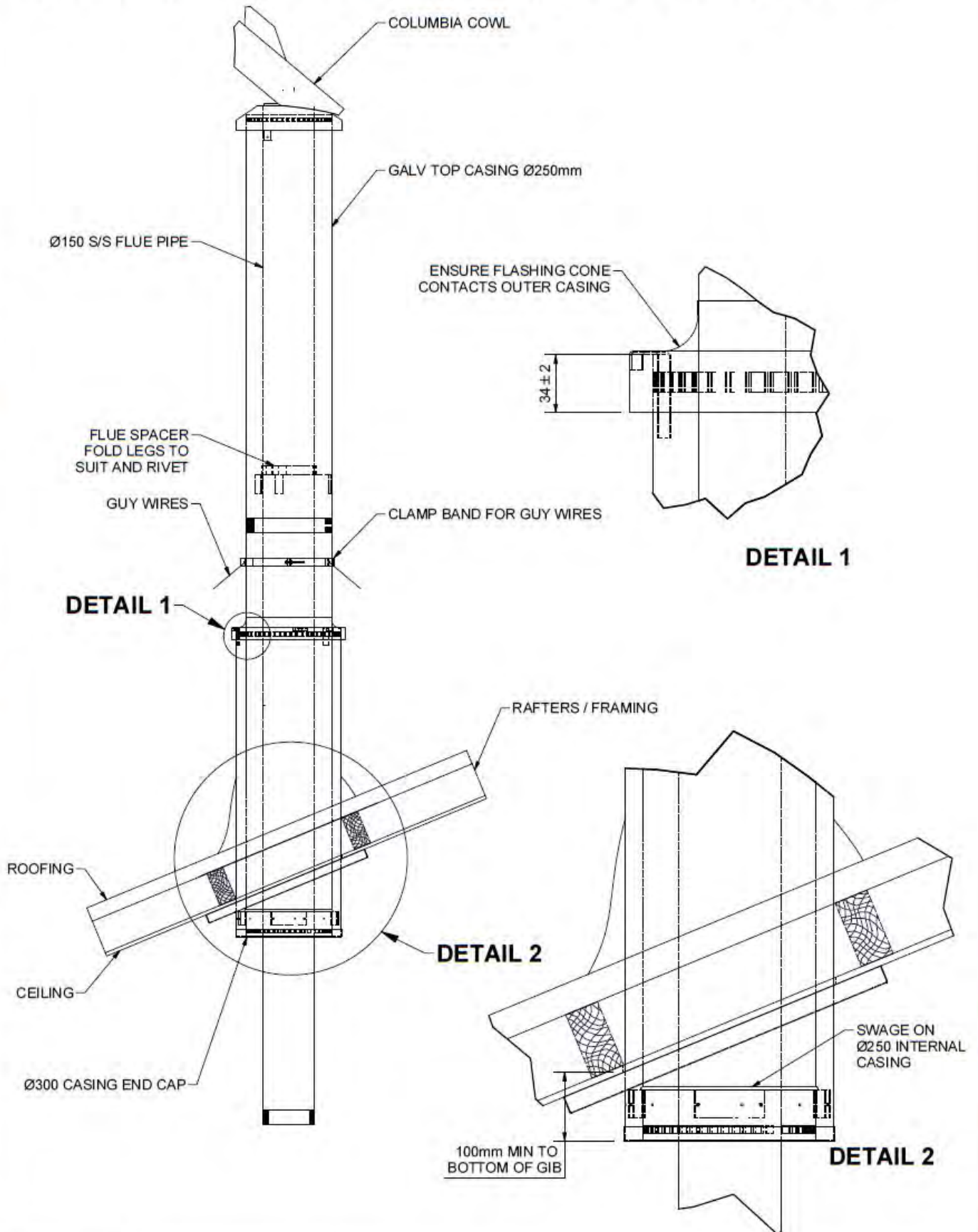

# HeatSaver Flue Kit Certificate



P.O. Box 687, NELSON,  
NEW ZEALAND

PHONE (03) 547 7347  
FAX (03) 547 2909  
EMAIL: info@appliedresearch.co.nz  
WEB: www.appliedresearch.co.nz

Report 09/1943

January 27th, 2009

Page 1/1

Customer: W.H. Harris Ltd.  
41 Braddon St.  
P.O. Box 4043  
CHRISTCHURCH

P701/1

COPY

Accreditation

Laboratory Registration Number 395

This laboratory is accredited by International Accreditation New Zealand (IANZ). The tests reported herein have been performed in accordance with the terms of our accreditation. This accreditation does not extend to any opinions or any interpretations of test results contained in this report.



IANZ has a Mutual Recognition Arrangement (MRA) with the National Association of Testing Authorities (NATA), Australia, such that both organizations recognize accreditations by IANZ and NATA as being equivalent. Users of test reports are recommended to accept test reports in the name of either accrediting body.

Compliance Certificate

Appliance: HeatSaver 150 mm Diameter Flue Kit

Test Standard: AS/NZS2918:2001 Appendix F

Full Report: 02/749R

(The full report contains the information on the test methods, details of the appliance tested and the results of the test)

This report:

Prepared by: W. S. Webley

W S Webley

Approved by: W. S. Webley

W S Webley

Release Date:

2/3/09

This report must not be reproduced except in full. Results are based on material and information supplied by the client. Applied Research Services Ltd shall not be liable in respect of any loss or damage (including consequential loss or damage) resulting from the use of reports prepared by them. Results issued in electronic form are subject to confirmation by issue of final report.

# Lighting Procedure

It is important to follow these steps to ensure the fire will operate as intended and to ensure a clean and efficient light up.

## What you will need:

- A. Approximately 16 pieces of kindling wood, about 1kg in weight (total)
- B. 4 x pieces of small sized wood (**intermediate load 1**), approximately 300mm in length, 1.2kg in weight (total)
- C. 4 x pieces of medium sized wood (**intermediate load 2**), approximately 300mm in length, 2.5kg in weight (total)
- D. 3 x natural fire lighter cubes
- E. Matches



**Important:** Ensure installation instructions have been adhered to before lighting the appliance.

**Reminder:** For your comfort, it is advised that you light your first fire with the windows open to allow the escape of paint fumes. This will normally happen for the first 30 to 60 minutes of the first burn. Ensure the fire is run at a high temperature during this period.



**D**

**Natural fire lighters**

### Step 1. Loading the wood for lighting

Place the 4 pieces of small wood (intermediate load 1) across the bottom. Then stack the 16 pieces of kindling wood in a 'cross stack' style on top of the intermediate load 1 with the 3 fire lighters placed on top of the kindling wood as shown.

## Lighting Procedure Continued



### Step 2. Light the fire lighter cubes

Light the 3 fire lighter cubes. Once the fire lighters have caught well alight, the main door can be fully shut.



30 mins



### Step 3. Load intermediate load 2 (4 pieces)

After approximately 30 minutes (or when the fire has burned down to red embers with minimal yellow flame), the fire is ready for the next load.



Load the '**intermediate load 2**' onto the embers and close the door.

## Lighting Procedure Continued



30 mins

### Step 4. Regular loading

After approximately 30 minutes, your fire is ready for regular loading of wood. It is recommended that you use a minimum 3 to 4 pieces of wood when reloading your fire.

## Reloading Procedure

It is important to note that when and how you reload your fire is important. Please follow these steps when reloading.

The door should not be opened until the wood inside has burned down to red embers and large yellow flames are minimal. The goal is to burn your wood in cycles for the cleanest and most efficient burn.

- If the fire has been on low, turn the fire onto the high setting for 5 minutes before reloading.
- Place the wood in the 'front to back' orientation for the Coleridge model and 'left to right' for the Kanaku model, and ensure that the size of wood is appropriate for your firebox.
- Do not overfill your fire box with wood. You should fill your firebox only to about 2/3 capacity, approximately 2 to 4 pieces depending on the size.
- Allow the wood to burn right down to large red embers with minimal yellow flame before repeating the process.

## Appropriate Firewood

Your Woodsman wood fire is designed to burn logs from trees which would typically be sourced from a reputable wood merchant as firewood.

The most common species is radiata pine, which is a soft wood. Other common species of wood like macrocarpa are also appropriate to use and some hard woods like eucalyptus (bluegum) can also be used.

The size of the wood will vary, but the typical length should be from 200mm to 350mm and the diameter around 100mm to 150mm.

The wood should be appropriately seasoned, which will depend on how it is stored, but the moisture content should be below 25% before use.

Your Woodsman wood fire is NOT designed to burn anything other than typical firewood as stated above, at the risk of damaging your firebox and voiding the warranty.

Do not burn, treated wood, building off cuts, drift wood, rubbish, garden waste, coal, old man pine (or other very resinous woods) or anything other than typical fire wood. If you need further clarification on a fuel, please contact Woodsman or your retailer before using it.

## Creosote Formation

A small intense fire is preferable to a large smouldering one, to reduce the amount of creosote. When wood is burned slowly it produces tar and other organic vapours, which combine with expelled vapour to form creosote. These creosote vapours condense in the relatively cool flue of a slow burning fire. As a result, creosote residue accumulates on the flue. When ignited, this creosote makes an extremely hot fire.

The flue should be checked at least every 2 months, during the burning season, to determine if a creosote build up has occurred. If this is the case, it should be removed by a chimney sweep to reduce the risk of an unexpected flue fire.

Your appliance has been designed to produce low levels of creosote at high and low settings.

**In the event of a chimney fire, close the firebox door, fully close the heat control, vacate the premises and call the fire service.**

## Storage of Fuel

Do not store fuel within installation clearances or within the space required for refuelling or ash removal. Wood should always be stored in a dry place out of the rain. We recommend your wood be seasoned for at least 6 months before use. Dry wood also burns hotter and more efficient than wet wood.

## Door Catch Adjustment

From time to time, your door catch may need to be adjusted to ensure a tight seal. The seal in the door is a fibreglass door rope and will compress over time. To adjust the door catch, undo the nut on the door assembly and redistribute the 4 washers to either tighten or loosen the catch. The door rope will need to be replaced during the life of the fire and you may need to loosen the catch at that time.

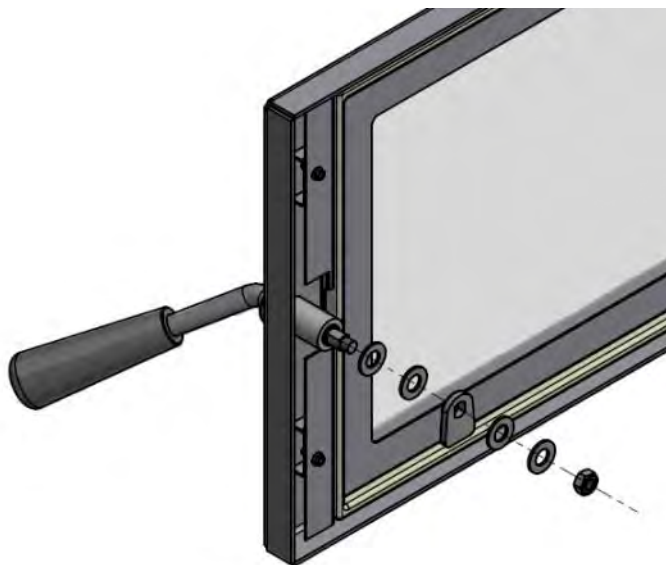

# Caring for your Fire & Maintenance

## **Door Glass**

- Ensure logs are not too long for the depth of the firebox. Do not attempt to close the door if a log is protruding from the front of the firebox opening.
- A broken glass is caused by the door being closed onto a full firebox or logs not correctly placed into the fire.
- Wiping your glass regularly with the provided glass cleaner wipe when cold will keep the glass clean. The wipe is designed to be used dry and buff the glass clean.

## **Door Rope**

- The door rope will need to be replaced from time to time. When replacing the rope or if the door rope becomes loose, press the door rope firmly back into the retainer. Flue cement or maniseal may be needed to help keep it in place.

## **Cleaning the Outside of the Fire**

- Woodsman fires are finished in a high temperature paint. Only use a damp cloth (no chemicals) when cleaning the outside of the fire. If any scratches occur, you can easily touch up the fire with an aerosol can of matching paint. This is available from your retailer or Harris Home Fires.

## **Cleaning the Flue**

- Keeping your flue clean is important. We recommend that you have your chimney swept at least once a year. A blocked flue not only effects the performance of the fire, but can also be a hazard as you are susceptible to chimney fires.
- Poor quality and wet wood will increase the number of times you will need to clean the flue. Good quality wood is important.

## **Cowl Maintenance**

- Your Columbia Cowl is fitted with a Teflon Sleeve to reduce noise and wear. The Teflon Sleeve may need to be replaced over the life of the fire and should be checked during an annual service or when the flue is cleaned. If the shaft is dry and dirty, it should be cleaned back to a bare metal finish and a thin layer of graphite or high temperature grease applied before replacing the Teflon Sleeve.
- Older versions of the Columbia Cowl do not have a Teflon Sleeve and require re-greasing one to two times a year

## **Ash Level**

- It is important to maintain a 2 - 3cm level of ash in the bottom of the fire for insulation purposes. But do not let the level get too high as you run the risk of logs and coals falling out of the fire. You also get less wood in the firebox.

# Consumables

Some parts of your Woodsman fire are considered consumable. They are designed to be replaced as they will degrade over time. The life of the consumables will vary depending on;

- Frequency of use. How often is the fire used?
- Rate of burn. Is the fire burning on low or high the majority of time?
- Type of fuel. Some woods are much harsher than others.
- Level of ash.

General items that are considered consumables:

- Baffles
- Fire bricks
- Air tubes
- Glass seals and door ropes

It is very important that you replace these parts when they show sign of wear. They effect how the fire runs and you may increase your fuel consumption or lower your efficiency if not replaced, and can in some cases, damage the firebox. It is generally obvious once a part is in need of replacement. Steel components may split or large holes may appear and fire bricks may disintegrate. Fire bricks that are cracked but still remain in place are completely safe to use and only need to be replaced when they no longer remain in place. A cracked fire brick may still last years of use.

We recommend you check your fire visually several times a year for damaged components.

## Coleridge

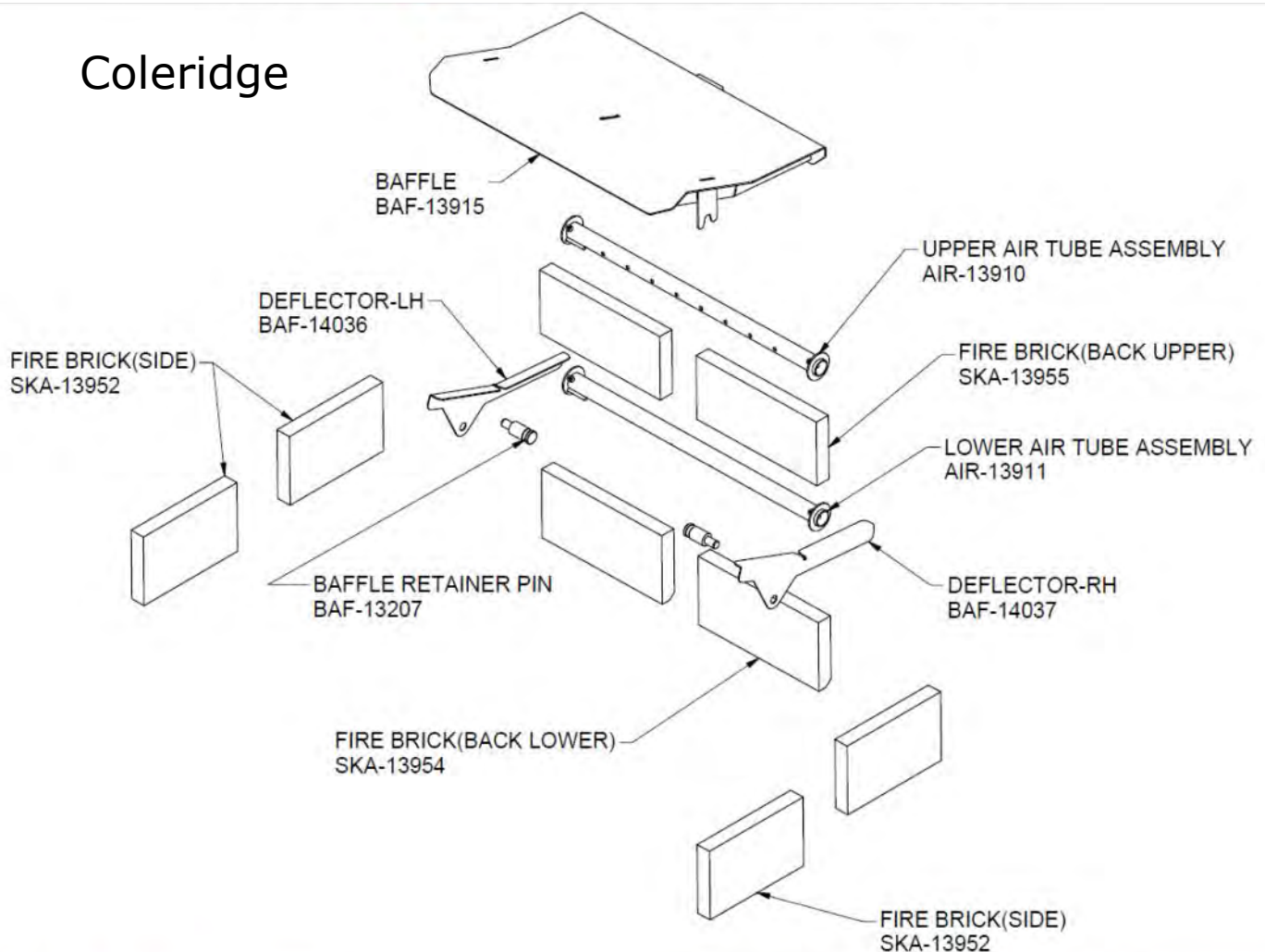

# Consumables

## Kanaku

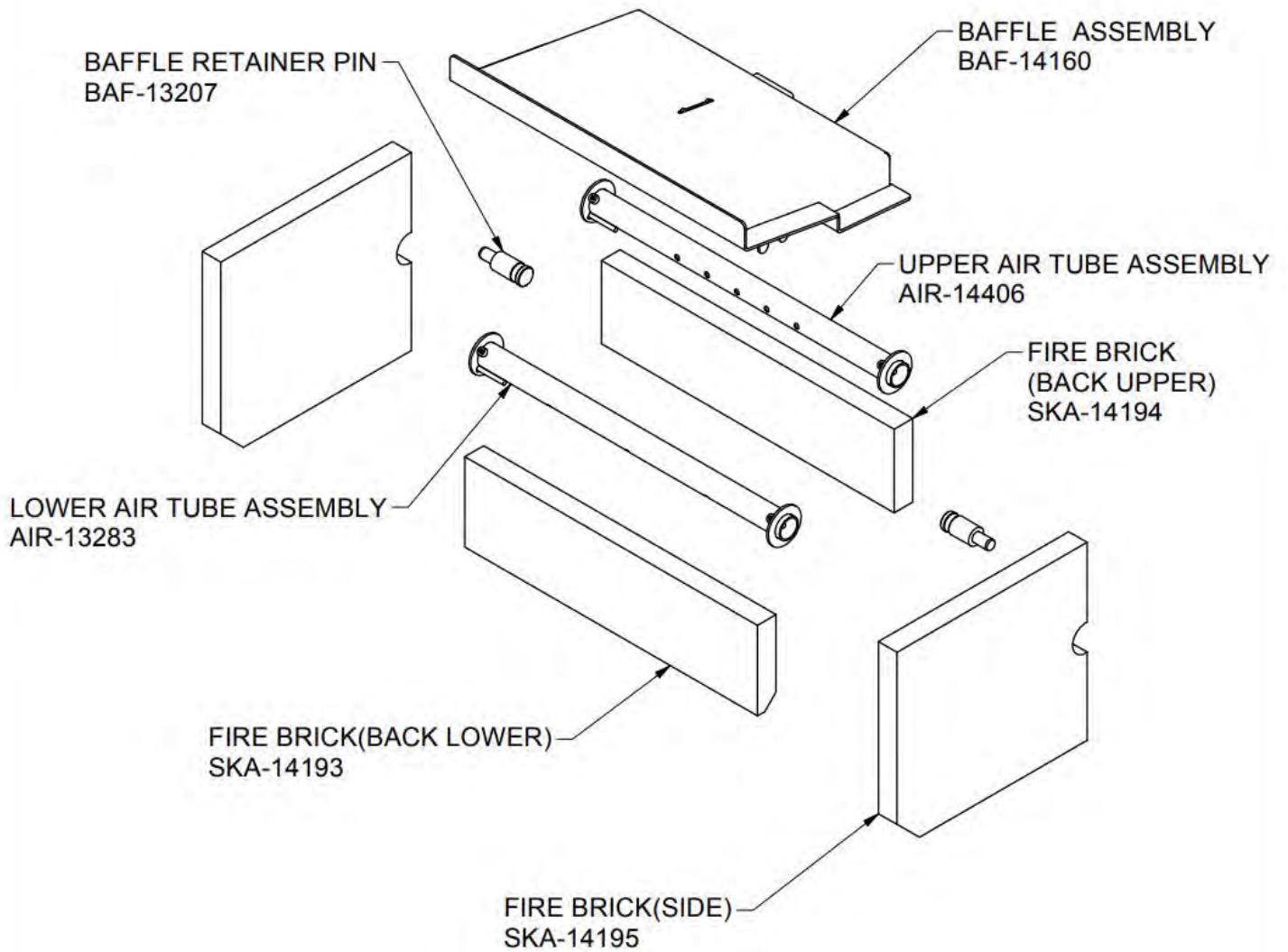

# Trouble Shooting

## **My fire won't turn down**

The first thing to be aware of is that some new clean air fires do not shut down like old fires. Old fires used to shut all the way off and the wood would just smolder.

Other reasons for this problem may be:

- Consumable parts have burned out and needs replacing, visually check.
- Door seal is not sealing properly and may need replacing. Take a thin strip of news paper, close the door on it at various spots, if the paper can be easily pulled out, then either a new door rope is needed or door latch needs adjusting by redistributing the washers on the door latch.

## **There is rust on my fire**

Rust appearing on your fire can only occur when moisture or water is present and has began to oxidize the steel.

- Identify where the water or moisture has come from and fix the problem.
- Lightly sand the effected area and use matching Woodsman aerosol high temperature paint to touch up.

## **My glass is dirty**

Your glass can get dirty easily if you use poor quality or wet wood or spend a lot of time with the fire on the low setting.

- Give the fire a good hot run on the high setting to burn off the residue on the door
- If that fails, there are special cleaners especially for this purpose or oven cleaner works well. Do not get chemicals on the paint work.

## **My fire smokes when I open the door**

There are many reasons which may cause this symptom and it is often a process of elimination to remedy the problem.

- Your flue length may be too short. Even though it may be of legal length, every installation is different and you may require an additional length of flue.
- Your flue may be blocked, have the flue looked at.
- The baffle may not be in place correctly, visually check to see if it has moved.
- You may need a cowl like the Columbia cowl to help encourage draw, especially where there are environmental problems like high winds.
- Your flue may be getting too cold. If the flue gases get too cold, they can struggle to be exhausted and when the door is opened, they find it easier to exit via the door than the flue. If you suspect your flue is getting cool, turn the fire up onto high for a few minutes before reloading, this will increase the temperature of the flue and increase the flue draught.
- Check that the installer has sealed **ALL** the flue joints and there are no gaps which will leak air into the flue, reducing the draw.

## **The paint has been damaged**

Paint finishes are not as durable as enameled finishes, but they are extremely quick and easy to touch up and the fire can look new in minutes.

- If damage has occurred to the paint, lightly sand the effected area and touch up using Woodsman High Temperature Paint.

## **My fire seems to be performing poorly, not burning well on high**

If your fire doesn't seem to burn well at the high level, check the following:

- Negative pressure, make sure there are no extraction devices like fans creating a negative pressure in the home.
- The flue length is long enough.
- The wood is dry.
- The flue is clean.



# WOODSMAN

## Coleridge & Kanaku Warranty

### 15 Year Firebox Warranty 2 Year Parts Warranty

Your Woodsman Coleridge and Kanaku fire is warranted for a period of 2 year to the original purchaser, from the date of purchase, against defective materials and workmanship which includes the firebox and all parts.

If a part defect occurs, return the part to the retailer or directly to Harris Home Fires along with a copy of the retailers receipt and a replacement part will be sent at no cost. The parts warranty does not cover the cost of fitting and replacing parts. Bricks that are cracked, but remain in place do not need to be replaced and are not covered by warranty.

If a firebox defect occurs, either contact the retailer or Harris Home Fires and it will be repaired or replaced at our discretion with all costs covered.

This warranty does not cover damage caused by mishandling, misuse, failure to follow the manufacturer's installation and operating instructions, or work done by others, such as installers, or plumbers etc. The manufacturer shall not be responsible for site conditions such as insufficient draught, downdraughts, or routine servicing and adjustments.

Damage caused by the failure to replace consumables like air tubes, baffles and fire bricks or not burning the recommended fuel, may void the warranty.

Your Woodsman Coleridge and Kanaku firebox is then covered by a further 8 year warranty against defective materials and workmanship during normal domestic use.

In the case of a claim after the second year, this warranty covers the cost of replacement or repair at the manufacturer's discretion and includes freight, painting and all required refurbishment.

Your Woodsman Coleridge and Kanaku is then covered by a further 5 year warranty on the fire box against defective materials and workmanship during normal domestic use.

In the case of a claim after the first 10 years, It shall be the owner's responsibility and expense to have the fire disconnected and ready for pickup from onsite or another suitable location or deliver the WOODSMAN fire to either the dealer from whom it was purchased or directly to Harris Home Fires. Harris Home Fires will pick-up, repair and refurbish the fire, including painting as necessary and deliver the fire back to the customer.



Harris Home Fires  
41 Braddon St  
Addington  
Christchurch 8024  
New Zealand  
Email sales@hhf.co.nz

P O Box 4043  
Christchurch 8140  
New Zealand

**Phone** 03 366 1796  
**Freephone** 0800 3661796  
**Fax** 03 366 1795